

An aerial photograph of a large-scale industrial construction project. In the center, a large, circular, white metal structure is being hoisted by a crane. The structure has a complex internal framework. To the right, a tall white crane stands on a concrete pad. In the foreground, a yellow crane is positioned near a large blue building under construction. The building has a flat roof and is surrounded by various construction materials and equipment. The background shows a mix of green fields and industrial buildings under a clear blue sky.

**Richmond
Engineering
Works**

An American Engineering Company

Railcar Dumpers and Train Positioners

www.richmondengineering.com

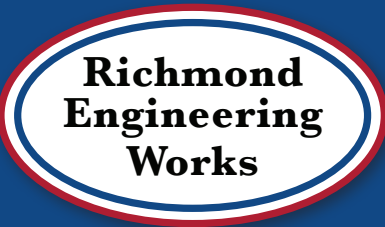

Richmond Engineering Works

For All Your Bulk Material Handling Needs

Rotary Car Dumpers

Following is a list of companies which have utilized Richmond Engineering Works Services:

- Alcoa
- American Electric Power (AEP)
- Cargill
- Consol
- CSX Railroad
- Detroit Edison
- Entergy
- First Energy
- Louisville Gas and Electric
- MidAmerican Electric
- Norfolk Southern
- NRG Energy
- Oklahoma Gas & Electric
- Port of Corpus Christi
- Westar Energy
- Xcel Energy

About Us

Richmond Engineering Works was formed in 1996 by five engineers who were formerly employed by Dravo-Wellman in the bulk material handling business. In the early years our focus was primarily electrical and controls upgrades. Our projects included not only bulk material handling machines but expanded to conveying systems, water treatment systems and ash handling systems. We also upgraded many unique and one of a kind systems, such as carbon block presses, vacuum annealing lines and cut-off saws.

In 2009 we added several experienced mechanical/structural engineers to our staff. In 2011 we received our first contract to design, build, and install a rotary car dumper. The dumper was completed in 2012. In 2013 we designed and supplied two of the most powerful Train Positioners in the USA. As of June 2016 we have successfully completed three new Rotary Car Dumpers with two more in the pipeline. Our staff now numbers over 30 engineers, technicians, and drafters. We have over 300 man years of experience in the design of material handling machines. Our engineers still travel to customer's sites to perform inspection an upgrades giving them first-hand knowledge of the performance of our designs as well as addressing any day to day problems they may be experiencing

Experience With

MANUFACTURING CONTROL SYSTEMS

- Conveyor Automation
- Baghouse and Dust Collection
- Pharmaceutical Sterilization
- Reclamation Control
- Industrial Motor Control Centers
- Building Energy Management
- Air Pollution Control Systems
- Mimic Panels and Operator Interfaces
- Hydraulics
- Mine Monitoring
- CVA Lines
- Power Distribution
- Water Treatment
- Ash Handling
- Concrete / Sludge Pump and Flow
- Tripper Automation
- Titanium Grinding Lines
- Industrial Machine Wiring
- Cement Systems
- Steel Manufacturing
- Wastewater Treatment

BULK MATERIAL HANDLING SYSTEMS

- Continuous Barge Unloaders
- Bunker Filling Operations
- Stacker / Reclaimers
- Mobile Hoppers
- Barge Haul
- Coal Handling
- Coal Bunkering
- Trippers
- Rotary Car Dumpers
- Coal Receiving
- Rail Car Positioners
- Ship Loaders / Unloaders
- Clamshell Barge Unloaders

MATERIAL HANDLING EQUIPMENT & SYSTEMS

- Belt Feeders
- Weighing Systems
- Palletizers
- Measurement Controls

INSPECTIONS • STUDIES • SURVEYS • FIELD SERVICE

Richmond Engineering Works offers complete state of the art engineering, fabrication and installation of Rotary Railcar Dumpers. Our designs are innovative and include the latest technological advances. Our Dumpers are designed for heavy duty service with high operating reliability rates and maintenance friendly features.

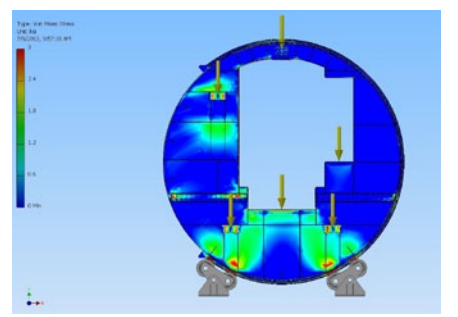

Our Dumpers are manufactured and assembled with strict runout and vertical alignment tolerances. Major components such as endrings, clamps and rear truss are pre-assembled for fit up prior to shipping for ease of assembly.

- Rack and Pinion Drive Gears
- Chain Drive
- Automatic Grease Systems
- Dust Suppression
- Bottom Dump Grizzly on Platen
- Fixed or Shifting Platen
- Shock absorbing return stop buffers
- Hydraulic Clamps
- Gravity Mechanical Clamps
- Breakaway Clamp Heads
- Quick Change Trunnion Wheels*
- Clipped or Bolt Thru End Ring Rail
- Rolled Tee or Welded Tee End Ring

*Quick Change Trunnion Wheel Design is Patent Pending

Breakaway Clamp Heads

Fully retractable to clear locomotive. Easily reset with replaceable shear pins. Extended head width to 10 inches (250mm) to minimize contact pressure and damage to railcar top sill.



Patent Pending "Quick Change Trunnion Wheel" Design

Includes double grease purge seal design and heavy duty Timken AP bearings. Designed to facilitate easy and quick removal of trunnion wheel systems without having to pull wheel or equalizer pins.



Safety Lock Rack

Used during maintenance activities to prevent Dumper from rotating and can be installed at any angle of barrel rotation.

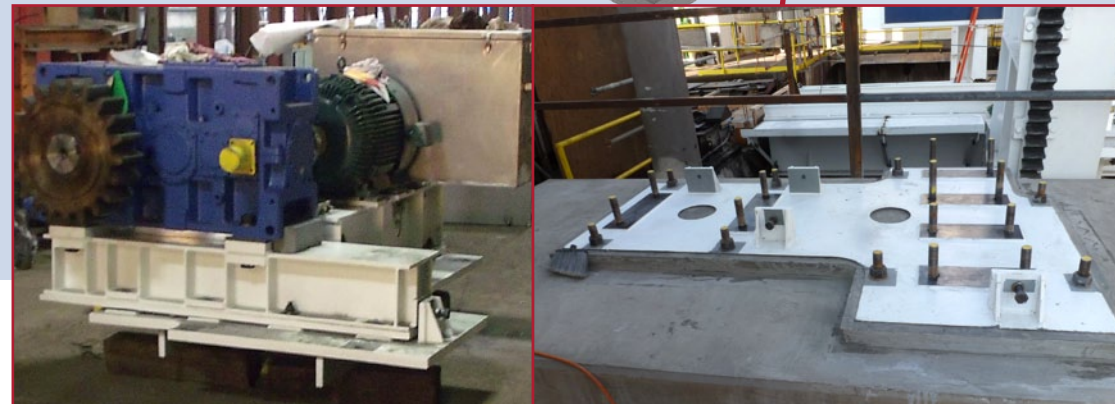

Drive Base

Unitized drive base design mounted on the embedded slide plate. Allows for easy adjustments to gear alignment without having to disassemble and re-align individual drive components such as motor, gear reducer and brake.

UHMW Strips

Abrasion resistant UHMW (Ultra High Molecular Weight) polymer. Has low coefficient of friction and protects sidewalls of railcars.



Deflector Plates

Abrasion resistant steel. Directs material away from trunnion wheels and sill beams.



Return Stop Shock Absorbing Buffer

Designed to stop a dumper returning to the seated position in an uncontrolled manner. The buffer is designed to dissipate the energy at full speed including motors powered.



Maintenance Platform

Extended maintenance platform for easy access to hydraulic hose and valve connections and electric control panel.



Hydraulic Clamp Cylinder

Heavy duty clamp cylinders with secondary double lip rod wiper seals and double lip main rod seals. Designed for easy replacement when necessary.

Train Positioners

Richmond Engineering Works offers a wide variety of Train and Railcar Positioners to suit your Indexing needs. Train Positioners include Rack and Pinion Gear or Wire Rope Drive for pulling capacities up to 400,000 lbs (1,800 kN), as well as smaller hydraulically driven 30 car train Positioners that travel in between the tracks. Our designs are innovative and include the latest in technological features. They are designed for continual heavy duty service with high reliability operation and maintenance friendly features.



160 Car Positioner - Rack & Pinion Drive – up to 400,000 lbs (1,800 kN) pulling capacity. Largest in the USA.



30 Car Positioner – Hydraulically Driven – Travels in between the track rails beneath the railcars.



130 Car Positioner - Wire Rope Drive – up to 300,000 lbs (1,334 kN) pulling capacity.

TRAIN HOLDING DEVICES

Richmond Engineering Works offers a variety of train holding devices with up to 150,000 lbs (667 kN) holding capacity. The devices consist of Holding Arms, Truck Locks, Wheel Grippers, and Retarders. They are activated either mechanically, hydraulically or pneumatically.



Holding Arm – 150,000 lbs (667 kN) holding capacity – Mechanically Operated.



Retarders – Air operated. Generous mis-spotting capability. Holding capacities up to 20,000 lbs (89 kN).



Model 100 Truck Locks – 100,000 lbs (445 kN) holding capacity – Hydraulically activated.

Electrical, Drive and Control Systems

The electrical engineers at Richmond Engineering Works are experts at integrating modern control equipment into existing plant control systems.



Drives are an essential part of the Dumper and Positioner controls. Flux Vector technology provides precise torque control of the AC motors to manage the overhauling loads generated by moving and dumping railcars.

Modern drives are also capable of communication with the control system via multiple platforms. The drive information is then available to operations and maintenance personnel for day-to-day operation of the equipment, troubleshooting, trending, etc.



A Programmable Logic Control (PLC) provides the functionality of the system and can be used to replace old style electro-mechanical relay controls. The PLC will communicate with drives, HMI and other plant systems to integrate the entire control system.

The Human-Machine Interface (HMI) is the connection between the control system and the operation and maintenance personnel. REW engineers continually strive to design the HMI to be intuitive and user-friendly to increase performance and minimize down time.

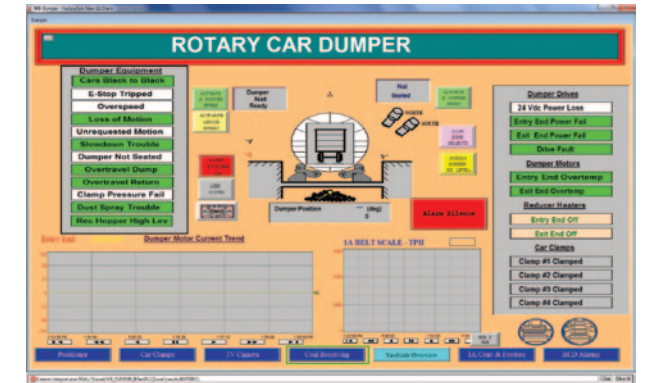
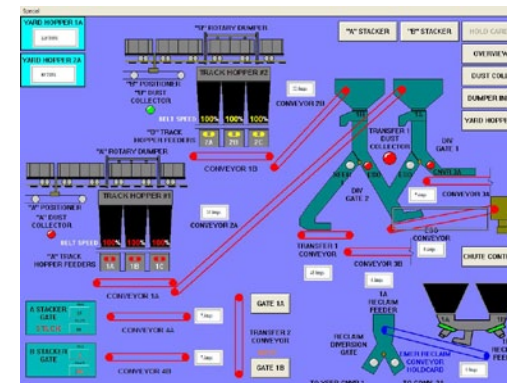

From drives and PLC control of a new REW Dumper or Positioner to upgrading outdated and obsolete controls of existing machines and entire coal handling systems, our engineers can design, program and implement a system that meets the individual needs of each customer.

Aftermarket Parts

Richmond Engineering can supply parts and services for all brands of Rotary Car Dumpers and Positioners. In many cases, we are able to provide re-engineered and upgraded parts for longer life and more reliability. Richmond Engineering also offers aftermarket services such as Equipment Inspections, Engineering Studies, Troubleshooting and Field Construction/Repair Assistance.



Bearing Base Chain Drive Assembly



Clamp Hydraulic Power Unit - On Board

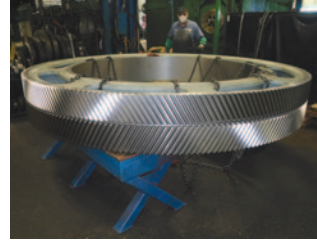

Positioner Drum Ring Gear



Positioner Drum Pinion Gear Assy



Mechanical Drive Chain and Clamp Chain



Equalized Trunnion Wheel Assemblies



End Ring Repair Section



Positioner Carriage Sheave Support Brackets



Positioner Drum and Gear Reducer



Gear Rack Inspection Template

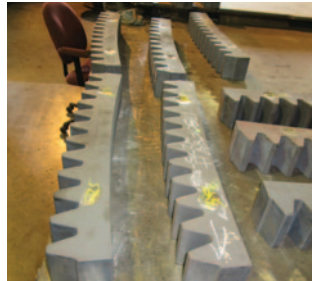

Gear Racks



Positioner Arm Replacement



Mechanical Clamp Brake Lever Arm

Rotary Car Dumper Parts

- End Ring Rails
- Equalized Trunnions
- Line Shafts
- Motor/Gearbox Upgrade
- On/Off Board Hydraulics
- Gear Racks
- End Ring Replacement
- Grizzly
- Mechanical Car Clamp Parts
- Off Board Hydraulics
- Pinion Gears
- Drive Chain & Clamp Chain

Railcar Positioner Parts

- Positioner Arm & Forks
- Draft Gear & OT Bumpers
- Equalized Travel Wheels
- Haulage Drum
- Rope Anchor / Clamp
- Truck Locks
- Arm & Sheave Support Brackets
- Drum & Pinion Gears
- Guide Rollers / Support Brackets
- Power Track
- Runway Rebuild
- Wire Rope

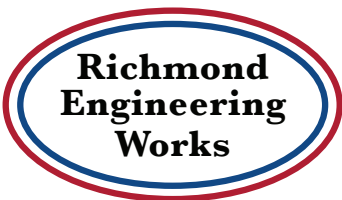

Main Office
1601 Parkway View Drive
Pittsburgh, PA 15205
Phone: 412-787-9640
Fax: 412-787-9645

Minnesota Office
9737 County Road #23 SE
Alexandria, MN 56308
Phone: 320-763-0830
Fax: 320-763-0895

Tennessee Office
404 East College Street Suite K
Dickson, TN 37055
Phone: 615-446-5880
Fax: 615-446-5836